

## Emergency Power-Off Circuits

The Emergency Power Off (EPO) button is a common feature in many medical, industrial, and data processing facilities. EPO circuits provide a fast, simple method of shutting down power to a room or piece of equipment. The EPO seems like a circuit function that requires little discussion. However, the simple EPO circuit presents several important design decisions.

### Safety First

An EPO circuit is intended primarily as a means to assure personnel safety. The EPO actuator (button) is located at a convenient location near an entrance / exit door or a central control area. Equipment can be de-energized quickly as required by:

- Equipment failure, resulting in fire or smoke
- Personnel electrocution
- Accidental personnel interaction with equipment (especially moving machines)

In these situations, the EPO is a critical part of the equipment safety design, and must be designed with ultimate reliability.

### Equipment Protection

An EPO circuit can also be relied upon to protect equipment when manual Power Switch-Off might be hazardous to personnel. For example, the ability to turn off system power during a flood, accidental sprinkler operation, or HVAC system failure could protect the equipment from extensive damage, while preventing personnel from contacting electrical equipment under hazardous conditions.

### Traditional EPO Circuits

Many types of circuit breakers may be ordered with a special actuator coil called a *Shunt Trip*. A shunt trip will cause a circuit breaker to open (trip off) when voltage is applied. Shunt Trip coils can be ordered in AC or DC voltages, and at many different voltage levels. (For example, 24 VDC, 24 VAC, or 120 VAC)

## Application Note - AN-16

Use of a traditional EPO circuit is simple and relatively inexpensive. The circuitry is rugged, and not prone to accidental tripping.

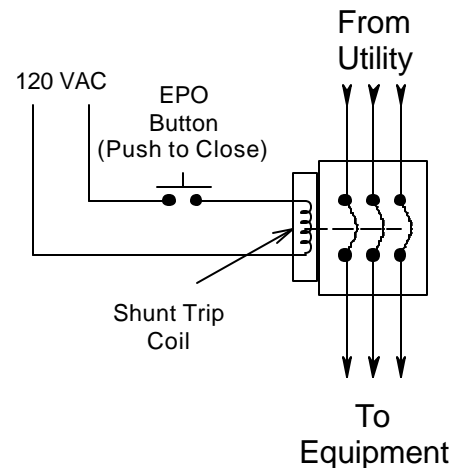

The traditional EPO circuit is not fail-safe, however. Several fault conditions can create a situation where the EPO will not operate to shut off the circuit. These include:

- Loss of the EPO circuit supply voltage
- Loose wiring or conductors in the EPO circuit
- A blown fuse in the EPO circuit

Since the EPO circuit is rarely called on to operate, the fault condition that would prevent the EPO from operating might occur weeks or months prior to the need to operate the EPO.

### A Fail-Safe EPO Circuit

A traditional EPO circuit can be called an Active Operate system - the Shunt Trip trips the breaker when voltage is applied.

If an EPO circuit were designed so that a loss of voltage caused operation, the EPO would be much safer. Under normal operation, the EPO would always disconnect the load. Fault conditions such as a wiring fault or device failure would also trip the EPO circuit. Finally, any voltage outage would operate the EPO Circuit.

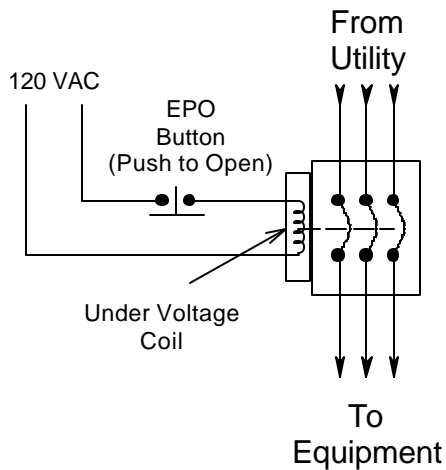

*Fail-Safe (Undervoltage) EPO*

Because the fail-safe, or undervoltage EPO circuit operates with any loss of voltage, it is possible that the EPO will operate due to factors such as short term voltage sags or drop-outs.

**Safety or Reliability ?**

The fail-safe EPO is safer than a traditional EPO, since its fault mode is to open the equipment circuit breaker. However, this safety assurance comes at a price. The EPO circuit is more prone to nuisance faults or tripping. If the load is sensitive to voltage outages or needs a long time to power up and restore to operation, using a fail-safe EPO might be undesirable.

Fortunately, there are ways to desensitize a fail safe EPO to reduce the nuisance trips and dependence on mains voltage. If a DC undervoltage shunt trip is selected, and a storage capacitor is used to hold up the DC supply voltage, the ability to ride through short outages and sags can be built in to the EPO circuit.

Ride-through times of 15 seconds can be incorporated with a reasonably sized storage capacitor. This length of ride-through is designed to ride through expected sags and outages as well as the transition time of a facility emergency power system (typically 10 seconds). Total loss of utility power will cause the EPO circuit to operate, however.

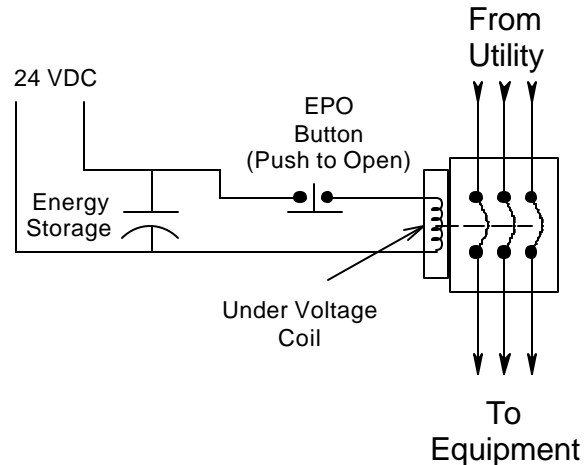

*Fail-Safe EPO with Ride-through*

Which EPO circuit is correct for your Power Distribution system? You can use the following diagram to assist in your decision. It's a small thing - but a properly specified EPO circuit can contribute immensely to equipment safety and reliability.

