

Reducing Footprint

The days of the large data processing center, with its dedicated power, HVAC, raised floor, and controlled environment are waning fast. Today's buzzwords in many industries are *Faster Installation! Lower Installed Cost! Smaller Footprint!*

The commercial, medical, and industrial environments have experienced increasing pressure to squeeze equipment into tighter areas. An effectively designed power interface can help to lower your overall space requirements, and get your equipment into the smallest space possible.

The Cost of Floorspace

Floorspace is at a premium at many sites, especially in older buildings and in large cities. Costs of \$500 - \$1500 per sq. ft. are not uncommon in some industries. Many times, footprint requirements are the critical factor in purchasing decisions. *Will this equipment fit into the available space?* If not, your customer may select a competitive product that has a lower installed footprint.

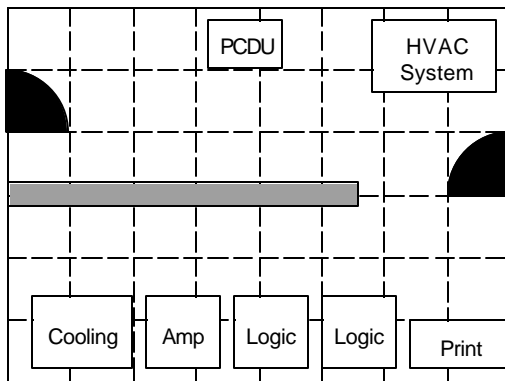

Many manufacturers advertise the minimal floorspace required by their equipment. In the sales brochure the system looks great, fitting into little more than a closet. The sales brochure may not be telling the entire story, however.

Application Note - AN-19

The Power Interface

Most equipment needs electrical power to operate. In a well-designed system this can be as simple as a circuit breaker on the wall. Other times, the electrical supply needs to include transformers, filters, surge suppressors, and distribution panels. All of these add to the floorspace and wallspace requirements of your system.

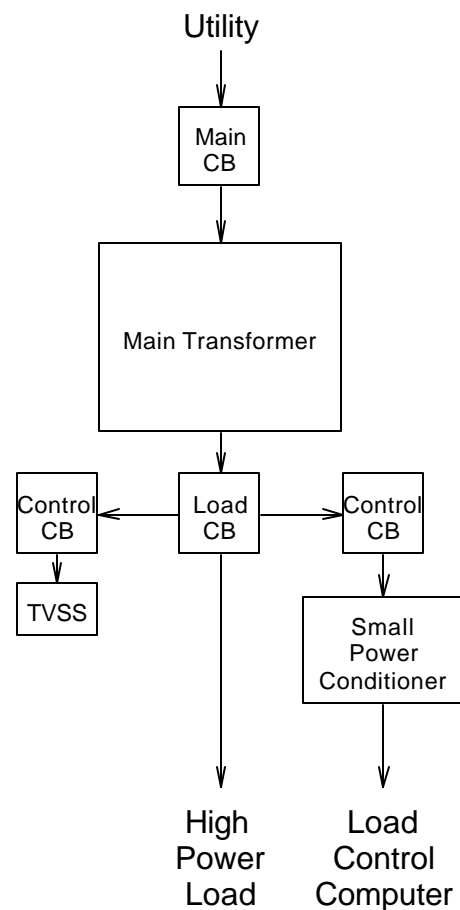

Even a simple mains interface can quickly turn into a large number of unattractive and floorspace hungry electrical boxes.

Compounding the floorspace squeeze is the National Electric Code (NEC), which requires 3 to 4 feet "working clearance" in front of electrical devices. This requirement greatly affects wall mounted equipment. A simple circuit breaker on the wall can require up to 6 square feet of empty floorspace in your installation.

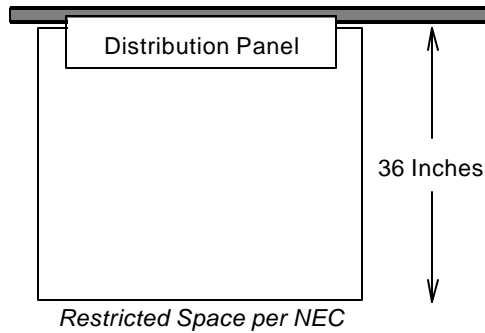

A designer can't compromise safety or violate the NEC, and as a result must dedicate a large amount of additional floorspace to the electrical installation.

Solving the Floorspace Problem

Manufacturers and end-users can recover floorspace with custom designed Power Distribution Units (PDU). These devices are compact, power interface cabinets that can include complete electrical adaptation:

- Circuit Breakers
- Transformers
- Distribution Panels
- Terminal Blocks
- Emergency Power Off (EPO) Control
- Surge Suppression
- Power Conditioning
- Receptacles
- On / Off Contactors

Simply grouping these devices into one cabinet results in a substantial footprint savings. However, some PDU manufacturers radically reduce the footprint by using special design techniques:

- Unique transformer designs and orientation
- Innovative layout techniques
- Computer Aided Design (CAD) of cabinet and mounting
- Custom designed enclosures

Power Conditioner or PDU ?

Power Conditioning devices can provide excellent benefits to sensitive equipment. Many manufacturers add a distribution panel to the output of a power conditioner, and call it a power distribution unit. Be cautious when selecting such a device - many of these devices can actually add footprint to your installation.

Only a power conditioner that is designed from the start as a PDU can take advantage of layout and component benefits to truly minimize footprint.

At What Cost?

Power Distribution Units are cost effective for a wide variety of applications. While simple component costs for a PDU may exceed those for distribution built-up on site, component cost is not the whole story.

OEM's must factor in multiple benefits from a PDU, including:

- Labor costs for a built-up distribution system (often at premium "downtown" rates)
- Installation time savings
- Footprint savings

When you factor in these costs, the PDU usually costs much less than building a power interface on site.

The Warning Signs

Your equipment or site may be a candidate for some footprint reduction with a PDU electrical interface if:

- Your site looks like an electrical closet
- The electrical inspector has visited the installation several times
- You need more floorspace to install the equipment than the brochure promises
- Your installation costs are higher than expected
- You are using more than 2 feet of wall space for electrical devices

TEAL Electronics has the expertise to minimize reduce your footprint with a custom mains interface designed into a compact power conditioning distribution unit.