

Ground Loops

One of the most difficult types of power problem to understand, diagnose, and resolve is the *Ground Loop*. All types of equipment are susceptible to this type of problem: medical, industrial, and data processing. Ground loops can cause data errors, component failure, lock-ups, and even cause safety hazards. It is no wonder that addressing ground loops is one of the highest priorities in the quest for high quality power.

What is a Ground Loop ?

All equipment is required to be grounded. Equipment and electrical system grounding is an important part of the safety philosophy of the United States, as detailed in the National Electric Code (NFPA-70) and UL Safety standards. These safety standards require most equipment enclosures, conduits, and exposed surfaces to be grounded.

Grounding is primarily used to ensure safety from fire and shock hazards. An important aspect of this protection is a reliance on multiple, redundant grounds. In this way, if one ground is accidentally removed or disconnected, additional safety paths exist. This redundancy has one undesired side-effect: it creates ground loops.

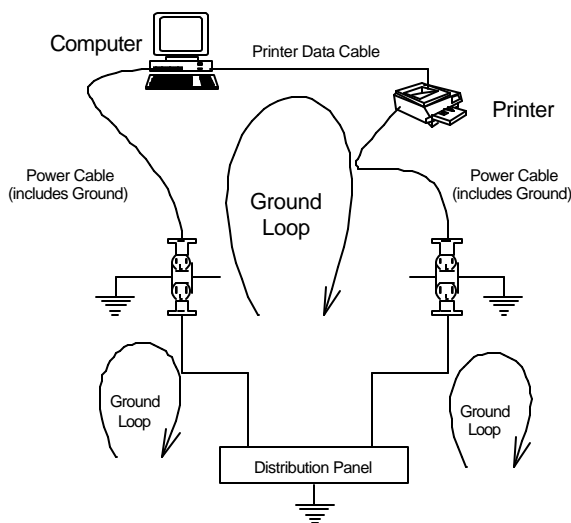

Application Note - AN-20

When ground loops are formed, the current that flows in the system grounds is unpredictable. This ground current can be caused by voltage differences, induction from other cables or devices, wiring errors, ground faults, and normal equipment leakage current. The currents can be DC, 60 Hz, or high frequency.

Ground Loop Problems

Ground loops cause specific equipment problems in three ways:

1. **Low energy currents** in the grounds generate voltages that cause data errors. These can be low frequency (such as 60 Hz hum on analog systems) or high frequency (electrical noise)
2. **High energy transients** choose data grounds instead of power grounds to clear to earth. These transients can be caused internally (switching or inrush currents) or external (utility or lightning transients). These transients cause equipment damage to drivers, receivers, as well as to the microprocessor system itself.
3. Ground loops are one cause of **Common Mode Noise** between phases and grounds. This noise is injected into power supplies, and can cause equipment damage and disruption.

Resolving Ground Loop Problems

There are many ways to address ground loop problems. Every electronic system has specific sensitivities and configurations that make a single ground philosophy difficult to develop. However, there are specific techniques that reduce or eliminate ground loops, and the effects of these on systems.

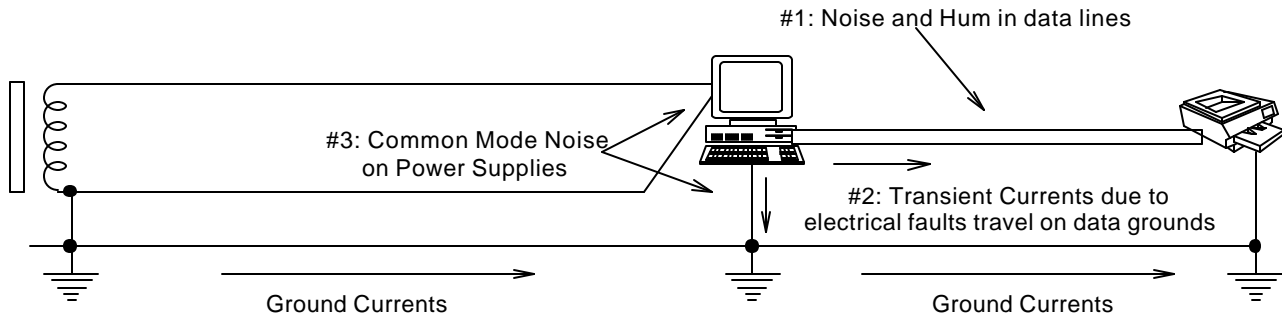

Improving the Ground Quality

Improving the quality of the grounding system reduces ground loop problems two ways. First, better quality grounds are by definition lower impedance grounds. These are much more likely to be used as a path for fault currents instead of data lines. In addition, the normal ground loop currents develop much lower voltage over a low impedance ground.

Use of full sized ground conductors (instead of reduced sized as permitted by the NEC) is one way of improving ground quality. Equalization grounding (such as a ground grid) is even better. All power and data grounds are connected to this grid so that grounds are equalized before they enter the sensitive equipment. However, this can only reduce, not eliminate, ground problems.

Isolation Transformers

Shielded isolation transformers are used to eliminate common-mode voltages. The ground currents and voltages are still present, but the transformer ensures that these do not create voltages that affect power supplies, or equipment. Shielded transformers are required to be grounded for safety, and as such do not "break" ground loops. However, they eliminate the symptoms of ground loops.

Data Line Isolation

Data line isolation can effectively break ground loops and prevent low and high level noise currents. Some data paths incorporate isolation automatically; other data lines can be isolated easily (video isolation transformers or optical isolation). Unfortunately, it is impractical to isolate some data paths.

Data Line Equalization

If data line isolation is not practical, the data line ground can be equalized with the AC power ground prior to entering the sensitive equipment. In this way, ground loops, and transients, are shunted away from the sensitive equipment.

A Coordinated Ground Philosophy

Ground loop problems can be reduced or eliminated with a coordinated ground policy. No single device or technique can address all problems. The critical components of this system include:

1. Shielded Isolation Transformer to eliminate common-mode voltages
2. Improved quality ground to the facility structure or ground system
3. Data line isolation to break ground loops outside of the system, or data line equalization to prevent loops through the sensitive equipment.

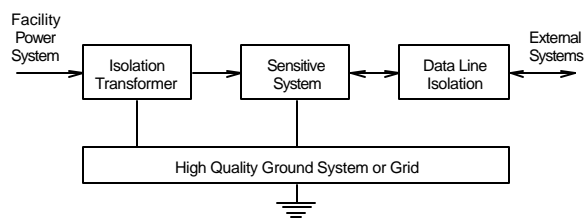

TEAL Electronics designs and manufactures power conditioners which are the foundation of a well designed equipment grounding system.